



Features:

- Duplex transceiver module
- Supports data rates of 6Gbps to 10.3125Gbps
- 850nm VCSEL transmitter and PIN receiver
- Typical reach of 82m on OM2, 300m on OM3 and 400m on OM4
- Compliant to IEC-60825-1, Class 1 laser eye safe
- Solder-down 1x12 electrical interface
- Screw posts for securing module to host
- SFF-8472 compliant control and diagnostics monitor interface
- -40°C to +85°C operating temperature
- -55°C to +100°C storage temperature
- Parylene conformal coating option



The RJ-10G-SX is ideal for harsh environment connectivity because of its low cost, availability, and wide operating parameters



COMMERCIAL AEROSPACE



MILITARY AEROSPACE



MILITARY TACTICAL

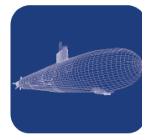

SUBSEA NETWORKING

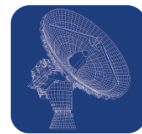

RADAR & SENSING



OIL & EXPLORATION

Absolute Maximum Ratings

Parameter	Symbol	Min.	Max.	Unit	Note
Maximum Supply Voltage	V _{CC}	-0.3	4.0	V	
Electrostatic Discharge, Data I/O pins	ESD		500	V	(1)
Storage Temperature	T _{sto}	-55	100	°C	
Operating Temperature	T _{op}	-40	95	°C	-40°C to +85°C standard
Relative Humidity	RH	0	95	%	(2)(4)
Hot Bar Soldering Temperature			260	°C	10 seconds, leads only, (5)(6)
Hand Lead Soldering Temperature			260	°C	10 seconds, leads only, (5)(6)
Conformal Coating		0.8	1.2	mil	(3)

- Notes:**
- 1) Proper ESD conditions should be employed while attaching RJ to the host board
 - 2) Non-condensing based on conformal coating
 - 3) See ruggedization notes on pg. 8
 - 4) RJ transceivers may be water washed. The process must be followed by an 80°C bake for one hour to ensure drying of any water inside the shell
 - 5) For optional solder post version, solder posts are intended for mechanical retention only and do not have to comply fully to IPC J-STD-001 Class 3
 - 6) The components should not undergo Reflow Soldering under any circumstances.

General Specifications

Parameter	Symbol	Min.	Typ.	Max.	Unit	Notes
Supply Voltage	V _{CC}	3.14	3.3	3.47	V	+/- 5%
Data Rate	BR	6		10.3125	Gbps	Balanced NRZ data protocols



Electrical Specifications ($T_{OP} = -40$ to $85^{\circ}C$, $V_{CC} = 3.14$ to 3.47 Volts)

Parameter	Symbol	Min.	Typ.	Max.	Unit	Notes
Total Module Power Dissipation	P_{DISS}			0.90	W	$0^{\circ}C$ to $+85^{\circ}C$
Total Module Power Dissipation	P_{DISS}			1.32	W	$-40^{\circ}C$ to $0^{\circ}C$
Transmitter						
Supply Current	I_{CC}			120	mA	$0^{\circ}C$ to $+85^{\circ}C$
Supply Current	I_{CC}			250	mA	$-40^{\circ}C$ to $0^{\circ}C$
Input Differential Impedance	R_{in}	90	100	110	Ω	
TX Single-Ended Input Voltage Swing	V_{in}	37.5		400	mV	
TX Disable Input Voltage	V_{DIS}	2.4			V	LVTTTL
TX Enable Input Voltage	V_{EN}			0.4	V	LVTTTL
Receiver						
Supply Current	I_{CC}			130	mA	
Rx Single-Ended Output Voltage Swing	V_O	125		225	mV	
Data Output Rise Time	t_r		35	45	ps	(1)
Data Output Fall Time	t_f		35	45	ps	(1)
Total Contributed Jitter	TJ			0.46	UI	
Signal Detect De-Assert	SD_D	2.4			V	(2)
Signal Detect Assert	SD_A			0.4	V	(2)
Signal Detect De-Assert Time	t_d	2.5	10	80	μs	
Signal Detect Assert Time	t_a	2.5	10	80	μs	
Serial Bus						
Data, Clock Input Low Voltage	V_{IL}	-0.3		$0.3 \cdot V_{CC}$	V	
Data, Clock Input High Voltage	V_{IH}	$0.7 \cdot V_{CC}$		$V_{CC} + 0.3$	V	
Data, Clock Output Low Voltage	V_{OL}			0.4	V	
Data, Clock Output High Voltage	V_{OH}	$V_{CC} - 0.4$			V	
Notes:						
1) 20% to 80%						
2) SD is LVTTTL. Logic 1 indicates normal operation; logic 0 indicates no signal is detected.						

RJ-10G-SX Host Pin Assignment

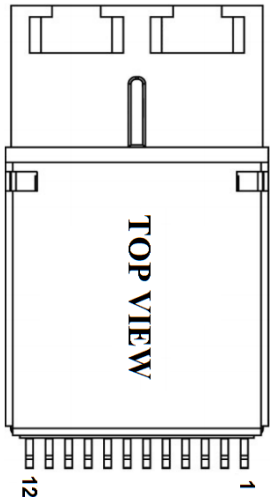

TOP VIEW

Pin	Symbol	Description	Logic/Protocol
1	TX-	Transmitter Data Input, Negative	CML
2	TX+	Transmitter Data Input, Positive	CML
3	GND	Ground	0V
4	TX_VCC	Transmitter Supply	3.3V
5	TX_DIS	Transmitter Disable	LVTTTL
6	SCL	I2C Clock	I2C
7	SDA	I2C Data	I2C
8	SD	Receiver Signal Detect	LVTTTL
9	RX_VCC	Receiver Supply	3.3V
10	GND	Ground	0V
11	RX+	Receiver Data Output, Positive	CML
12	RX-	Receiver Data Output, Negative	CML

Optical Characteristics (T_{OP} = -40 to 85°C, V_{CC} = 3.14 to 3.47 Volts)

Parameter	Symbol	Min.	Typ.	Max.	Unit	Notes
Transmitter						
Output Optical Power	P _{OUT}	-5		-1	dBm	(1,2)
Optical Wavelength	λ		850		nm	
Extinction ratio	ER	3	5		dB	
Relative Intensity Noise	RIN			-130	dB/Hz	
TX Mask Compliance	See TX Compliance Mask			(3)		
Receiver						
Receiver Sensitivity	RX _{SENS}		-13	-11.1	dBm	(3), BER = 1E-12
Receiver Saturation	RX _{SAT}	0			dBm	
Optical Center Wavelength	λ _C		850		nm	
Return Loss	RL	12			dB	
Signal Detect Assert	SD _A			-9	dBm	
Signal Detect De-Assert	SD _D	-22			dBm	
Signal Detect Hysteresis	SD _H	1		5	dB	

Notes:

- Class 1 Laser Safety per IEC-60825-1 regulations
- Measured with 2-5 meter patch cord consisting of laser optimized OM3 or OM4 fiber
- Measured using PRBS 2³¹-1 pattern

Application Schematics

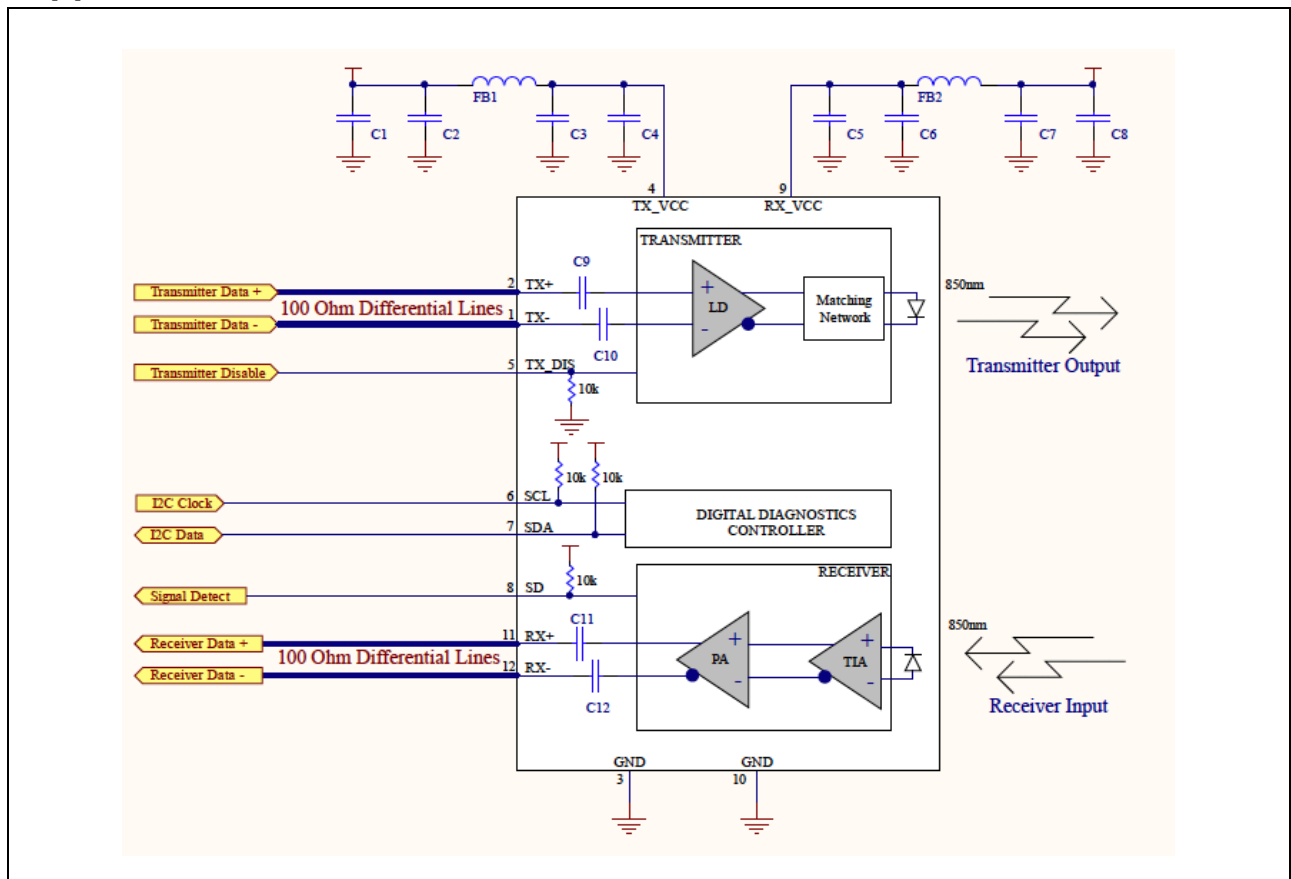



Address A0h Data Fields

A0h Address (dec)	# Bytes	Name	Description	Value (hex)
Base ID Fields				
00	1	Identifier	Type of transceiver	02
01	1	Ext. Identifier	Extended identifier of type of transceiver	04
02	1	Connector	Code for connector type	07
03	8	Transceiver	Code for electronic or optical compatibility	18
04				00
05				00
06				00
07				40
08				40
09				0C
10				40
11	1	Encoding	Code for high speed serial encoding algorithm	06
12	1	BR, Nominal	Nominal signaling rate, units of 100 MBd	67
13	1	Rate Identifier	Type of rate select functionality	00
14	1	Length (SMF, km)	Link length supported for single mode fiber, units of km	00
15	1	Length (SMF)	Link length supported for single mode fiber, units of 100 m	00
16	1	Length (50um)	Link length supported for 50 um OM2 fiber, units of 10 m	08
17	1	Length (62.5um)	Link length supported for 62.5 um OM1 fiber, units of 10 m	03
18	1	Length (OM4 or copper cable)	Link length supported for 50um OM4 fiber, units of 10m. Alternatively copper or direct attach cable, units of m	37
19	1	Length (OM3)	Link length supported for 50 um OM3 fiber, units of 10 m	1E
20	16	Vendor Name	SFP vendor name (ASCII)	43
21				4F
22				54
23				53
24				57
25				4F
26				52
27				4B
28				53
29				20
30				20
31				20
32				20
33				20
34				20
35				20
36	1	Transceiver	Code for electronic or optical compatibility	00
37	3	Vendor OUI	SFP vendor IEEE company ID	00
38				00
39				00
40	16	Vendor PN	Part number provided by SFP vendor (ASCII)	52
41				4A
42				31
43				30
44				47





45				53
46				58
47				XX
48				XX
49				XX
50				XX
51				XX
52				XX
53				XX
54				XX
55				XX
56				30
57	4	Vendor rev	Revision level for part number provided by vendor (ASCII)	30
58				30
59				30
60				03
61	2	Wavelength	Laser wavelength	52
62	1	Unallocated		00
63	1	CC_BASE	Check code for Base ID Fields (addresses 0 to 62)	XX
Extended ID Fields				
64	2	Options	Indicates which optional transceiver signals are implemented	10
65				14
66	1	BR, max	Upper bit rate margin, units of %	00
67	1	BR, min	Lower bit rate margin, units of %	00
68	16	Vendor SN	Serial number provided by vendor (ASCII)	XX
69				XX
70				XX
71				XX
72				XX
73				XX
74				XX
75				XX
76				XX
77				XX
78				XX
79				XX
80				XX
81				XX
82				XX
83				XX
84	8	Date code	Vendor's manufacturing date code	XX
85				XX
86				XX
87				XX
88				XX
89				XX
90				20
91				20
92	1	Diagnostic Monitoring Type	Indicates which type of diagnostic monitoring is implemented (if any) in the transceiver	68
93	1	Enhanced Options	Indicates which optional enhanced features are implemented (if any) in the transceiver	70
94	1	SFF-8472 Compliance	Indicates which revision of SFF-8472 the transceiver complies with	08
95	1	CC_EXT	Check code for the Extended ID Fields (addresses 64 to 94)	XX





PCB Design Guidelines

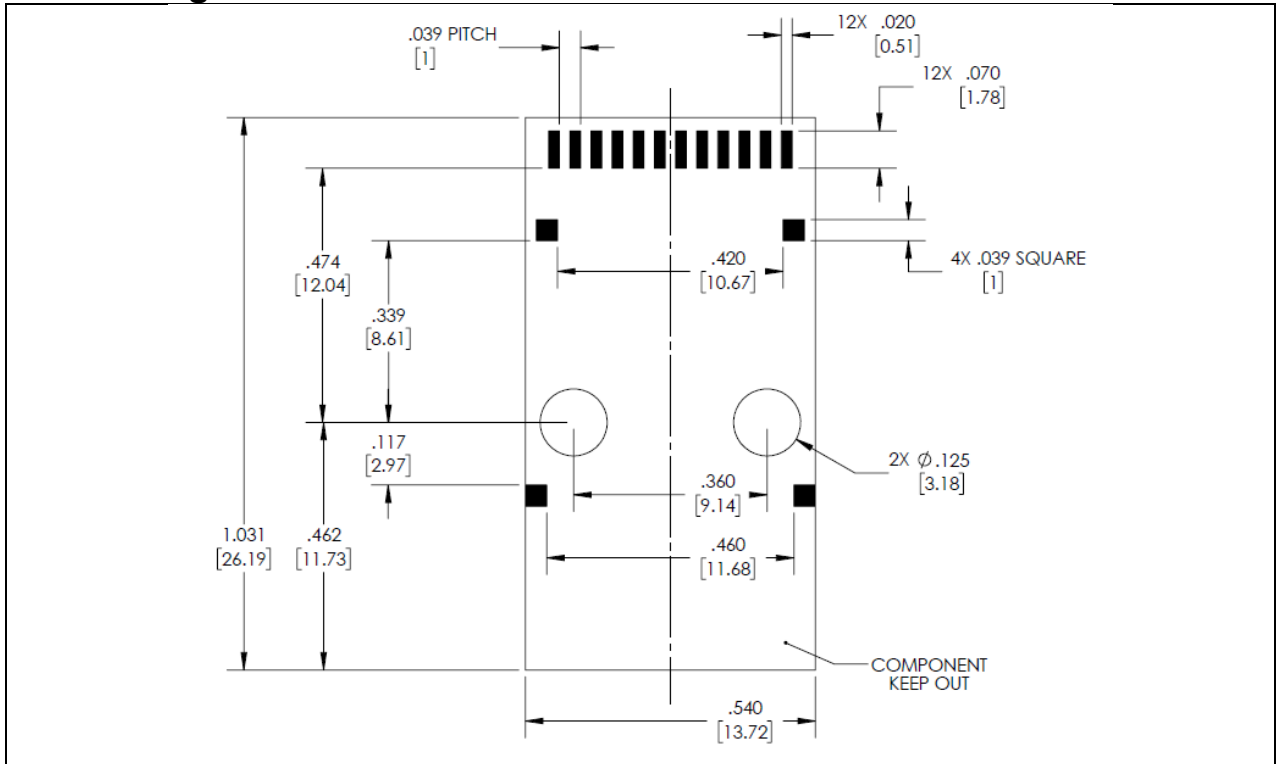

Panel Cutout

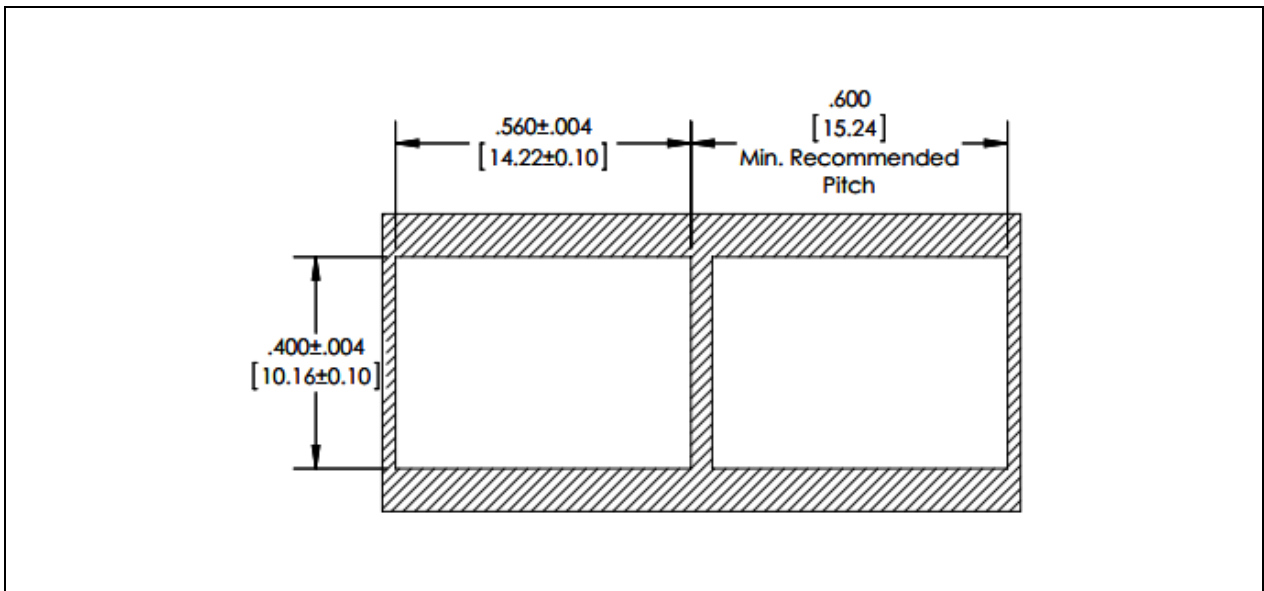

Standard Mechanical Dimensions

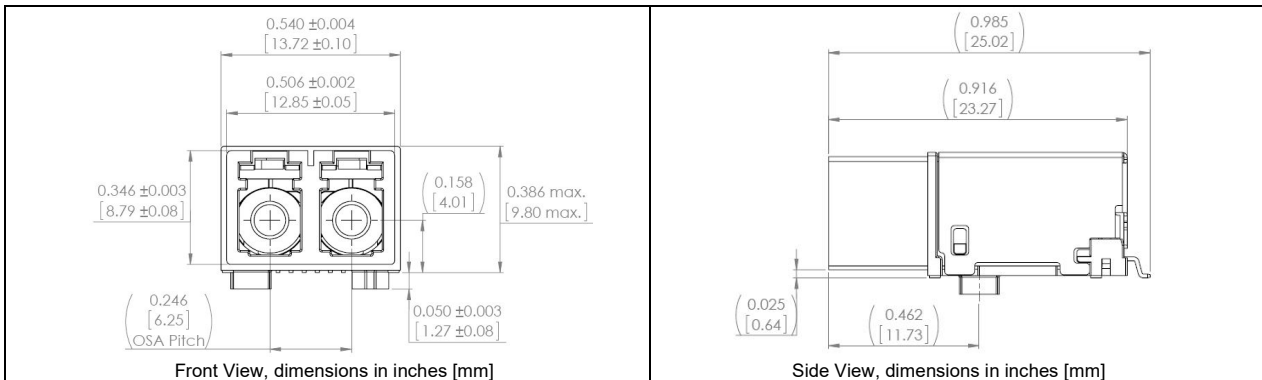

Mechanical Dimensions with EMI Shield

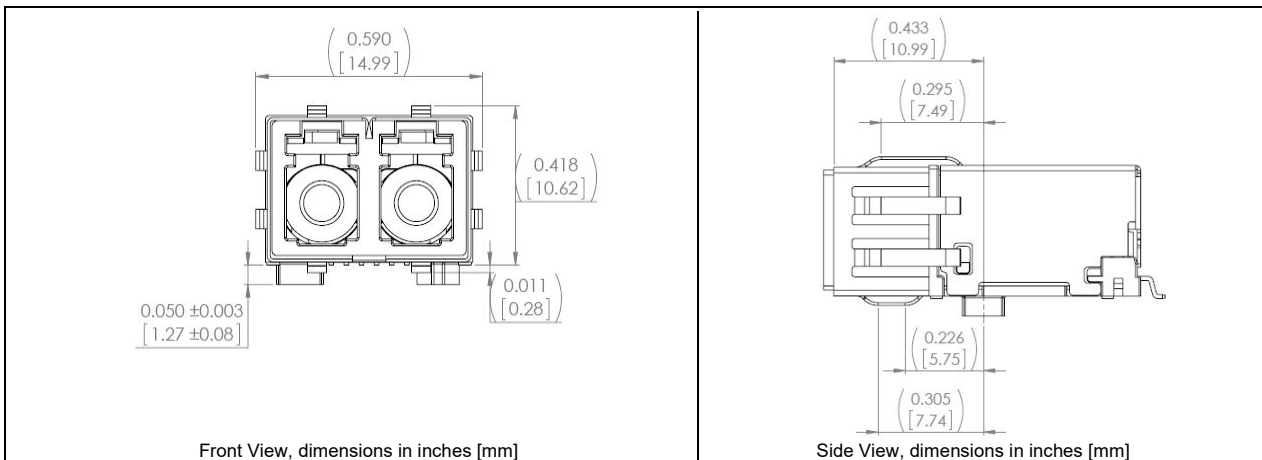

Mounting Hardware Guidelines

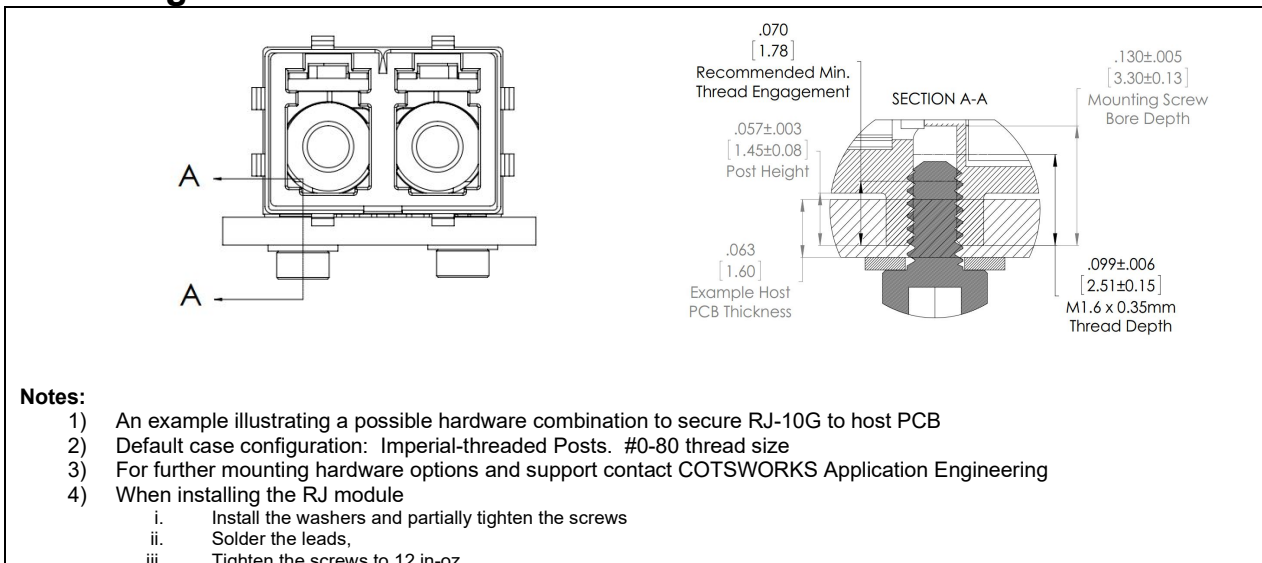



Ruggedization Notes

- Parylene C coating can be used for conformal coating with a 1.0 mil ± 0.2 mil thickness through a deposition process.
- Parylene Type C has a 5600 VPM rating, withstands high temperatures, and is extremely resistant to oil/dirt, and object impact.
- Contact COTSWORKS for all MSDS and case composition information.

Reference Information

1) IEEE Standard 802.3-2008, Section 6

Regulatory Compliance

- COTSWORKS transceivers are Class 1 Laser Products and comply with US FDA regulations.
- These products are designed to comply with the Class 1 eye safety requirements of EN (IEC) 60825 and the electrical safety requirements of EN (IEC) 60950.
- This part has an option for compliance with Directive 2011/65/EU covering restriction on certain hazardous substances (RoHS)
 - Contact COTSWORKS support for a product compliance matrix

Warnings:

Handling Precautions: This device is susceptible to damage as a result of electrostatic discharge (ESD). A static free environment is highly recommended.

Laser Safety: Radiation emitted by laser devices can be dangerous to human eyes. Avoid eye exposure to direct or indirect radiation

Ordering Information

RJ-10G-SX	-XX-	X	-X-	X	-X-	X
	Connector Type	Ruggedized Coating	Operating Temp Range	EMI Shield	RoHS Level	Mounting
RJ Form Factor						(<i>:</i>): Imperial Screw
10Gbps Max Data Rate			A: -40 to 85°C			U: Metric Screw
Short Reach (MMF)	(<i>:</i>): Standard LC LX: ARINC-801	(<i>:</i>): Non-coated R: Parylene	M: -40 to 95°C Z: -55 to 95°C	(<i>:</i>): No Shield E: Shield	(<i>:</i>): Lvl 5 6: Lvl 6	P: Posts

Example part number: RJ-10G-SX-R-A

[10 Gbps RJ Transceiver, 850nm, short-reach, Duplex LC connectors, Parylene-coated, Industrial operating temperature range]

Contact COTSWORKS for mechanical dimensional information and other configuration options.

COTSWORKS and the COTSWORKS logo are registered trademarks of COTSWORKS, INC. COTSWORKS reserves the right to change, alter, or revise this document without notice unless otherwise agreed to.

