



Features:

- 1.25Gbps bi-directional, single fiber transmission
- Industry standard MSA 2x5 electrical footprint
- Optional 2x7 electrical footprint for Digital Diagnostic support
- Digital Diagnostics per SFF MSA SFF-8472
- Simplex LC optical connector interface
- Rugged through-hole mounting and optional rear ground case posts
- Full-metal case to optimize EMI performance
- MIL-STD-883 mechanical shock and vibration compliant
- -40°C to +85°C operating temperature
- EN-60825/IEC-825/CDRH Class 1 compliant 1310/1550 FP Lasers
- +3.3V Power Supply
- Parylene C conformal coating option
- AC-coupled data inputs and outputs with necessary internal terminations



SFB-G-xx is ideal for harsh environments including military and aerospace applications



COMMERCIAL AEROSPACE



MILITARY AEROSPACE



MILITARY TACTICAL

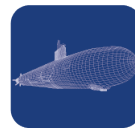

SUBSEA NETWORKING

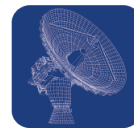

RADAR & SENSING



OIL & EXPLORATION

Absolute Maximum Ratings

Parameter	Symbol	Min.	Max.	Unit	Note
Power Supply Voltage	VCC	-0.5	5.0	V	
Operating Temperature	TOP	-40	85	°C	
Storage Temperature	TSTG	-55	100	°C	
Soldering Temperature	-	-	260	°C	(1)
Relative Humidity	RH	-	85	%	Non-condensing, (5)
MM Link Distance (62/125µm)	-	-	1000	m	(2)
SM Link Distance (9/125µm)	-	-	25	km	(3)
Conformal Coating	-	0.8	1.2	mil	(4)

Notes:

- 1) 10 seconds, leads only. The parts should not undergo wave soldering.
- 2) MMF links cannot include any air gaps, such as those found in expanded beam connections.
- 3) Assuming a fiber loss of 0.5dB/km.
- 4) Parylene C coating.
- 5) Based on conformal coating.



Electrical Specifications (T_{OP} = -40°C to +85°C, V_{CC} = 3.14V to 3.47V)

Parameter	Symbol	Min	Typ	Max	Unit	Notes
Transmitter Specifications						
Supply Current	I _{CC}	-	-	125	mA	(1)
TX Single-Ended Input Voltage	V _{SI}	100	-	1200	mV _{P-P}	AC-coupled
TX Input Differential Impedance	R _{IN}	90	100	110	Ω	
Transmitter Disable Voltage	V _{DIS}	2	-	V _{CC}	V	LVTTTL
Transmitter Enable Voltage	V _{EN}	0	-	0.8	V	(2)
Receiver Specifications						
Supply Current	I _{CC}	-	-	125	mA	(1)
Output Differential Impedance	Z _{OUT}	90	100	110	Ω	
Single-Ended Output Voltage Swing	V _{SE}	300	-	1000	mV	AC-coupled
Data Output Rise/Fall Time	t _r /t _f	-	-	260	ps	(4)
Signal Detect Output - Voltage Low	V _{SDL}	0.0	-	0.5	V	LVTTTL
Signal Detect Output - Voltage High	V _{SDH}	2.0	-	V _{CC}	V	LVTTTL
Notes:						
1. Maximum current is defined at maximum operating temperature at the maximum allowable V _{CC}						
2. Default is transmitter enabled using an internal 10k Ω pull-down resistor						
3. CML compatible, contact COTSWORKS applications engineering for further support						
4. Measured at P _{in} = -18dBm, 20%–80% values						
5. Option with Digital Diagnostics						

Pin Configuration

PIN CONFIGURATION			
PIN #	Symbol	Description	Notes
MS	MS	Mounting Studs	Chassis Ground
C	NC	No Connection	
A	SDA	Serial Data Interface I/O	Two Wire Data (Digital Diagnostics)
1	V _{EER}	Receiver signal ground	Common with Transmitter Ground
2	V _{CCR}	Receiver power supply	3.3V nominal
3	SD	Signal detect output	LVTTTL (Logic 1 = normal operation)
4	RD-	Receiver inverted data out	AC-coupled
5	RD+	Receiver non-inverted data out	AC-coupled
6	V _{CCT}	Transmitter power supply	3.3V nominal
7	V _{EET}	Transmitter signal ground	Common with Receiver Ground
8	TX _{DIS}	Transmitter disable	LVTTTL
9	TD+	Transmitter non-inverted data in	AC-coupled
10	TD-	Transmitter inverted data in	AC-coupled
B	SCL	Serial Interface Clock Input	Two Wire Clock (Digital Diagnostics)
D	TX Fault	Transmitter Fault Condition	If Implemented

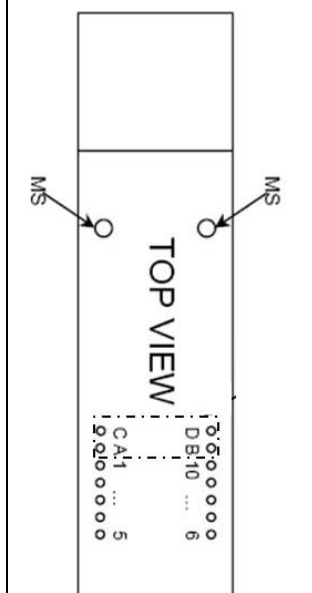

TOP VIEW

0.60" ... 0.20"

MS ... MS

CA1 ... 5

0.20" ... 0.20"

Notes:

- 1) Mounting studs and solder posts are chassis ground.
- 2) Mounting studs are swaged gold-plated pins for solderability.
- 3) Solder posts are an extension of the sheet metal case and are optional.
 - a. See plating note in "Ordering Information."
- 4) Only Pins 1–10 used for standard 2x5 footprint (Non-Diagnostic Capable)



Optical Characteristics (T_{OP} = -40 to 85°C, V_{CC} = 3.135 to 3.465 Volts)

Parameter	Symbol	Min.	Typ.	Max.	Unit	Notes
Transmitter						
Output Power: SMF	P _{o-SMF}	-8.5	-	-3	dBm	(1)(2)(3)
Output Power: MMF	P _{o-MMF}	-6	-	0	dBm	(1)(4)
Coupled Power Ratio	CPR	-	3	-	dB	
Output Center Wavelength	λ	1260	1310	1360	nm	1310 Tx/1550 Rx option (7)
Output Center Wavelength	λ	1500	1550	1600	nm	1550 Tx/1310 Rx option (7)
Output Spectral Width	σ	-	-	4	nm	RMS
Extinction Ratio	ER	9	-	-	dB	
Optical Rise/Fall Time	t _r /t _f	-	-	260	ps	20% to 80% values (6)
Optical Isolation		30	-	-	dB	BOSA transmitter isolation
Relative Intensity Noise	RIN	-	-	-120	dB/Hz	(2)
Total Contributed Jitter	TJ	-	-	150	ps	(2)(5)
Receiver						
Receiver Sensitivity	RX _{SENS}	-	-	-22	dBm	(5)
Receiver Saturation	P _{in}	0	-	-	dBm	(6)
Signal-Detect Assert	P _a	-	-	-17	dBm	(6)
Signal-Detect De-Assert	P _d	-38	-	-	dBm	(6)
Signal-Detect Hysteresis	-	1	-	6	dB	(6)
Wavelength of Operation	-	1500	1550	1600	nm	1310 Tx/1550 Rx option
Wavelength of Operation	-	1260	1310	1360	nm	1550 Tx/1310 Rx option
Notes:						
1. Class 1 laser eye safe, IEC-60825-1 compliant						
2. Compliant to IEEE 802.3z, Section 5 1000BASE-BX						
3. Measured at the end of a 2m SMF jumper						
4. Measured at the end of a 2m 62.5µm MMF jumper						
5. Measured with SMF at 2 ⁻⁷ -1 PRBS, BER= 10 ⁻¹²						
6. Measured using 9µm SMF and optical attenuator						
7. Measured with an Optical Spectrum Analyzer at 25°C						

Digital Diagnostics Information

COTSWORKS' SFF parts include additional pins to read and write I2C information per the MSA SFF 8472 specification. While typically implemented in pluggable modules such as SFPs, all that is required to enable this functionality are two additional pins and internal circuitry in the transceiver. The circuitry in the COTSWORKS' SFF is a microcontroller providing EEPROM storage and accessing optical and electrical information from the laser and receiver. The pinout for the transceiver appears on the previous page. For more information on Digital Diagnostics, visit <https://cotsworks.com/support-documents/digital-diagnostic-overviews/>



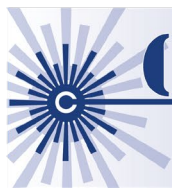

Address A0h Data Fields (SFB-G-35)

A0h Address (dec)	# Bytes	Name	Description	Value (hex)
Base ID Fields				
00	1	Identifier	Type of transceiver	02
01	1	Ext. Identifier	Extended identifier of type of transceiver	04
02	1	Connector	Code for connector type	07
03	8	Transceiver	Code for electronic or optical compatibility	04
04				10
05				10
06				02
07				42
08				00
09				0D
10				01
11	1	Encoding	Code for high-speed serial encoding algorithm	01
12	1	BR, Nominal	Nominal signaling rate, units of 100 MBd	0C
13	1	Rate Identifier	Type of rate select functionality	00
14	1	Length (SMF, km)	Link length supported for single mode fiber, units of km	02
15	1	Length (SMF)	Link length supported for single mode fiber, units of 100m	14
16	1	Length (50µm)	Link length supported for 50µm OM2 fiber, units of 10m	37
17	1	Length (62.5µm)	Link length supported for 62.5µm OM1 fiber, units of 10m	1C
18	1	Length (OM4 or copper cable)	Link length supported for 50µm OM4 fiber, units of 10m. Alternatively copper or direct attach cable, units of m	64
19	1	Length (OM3)	Link length supported for 50µm OM3 fiber, units of 10m	37
20	16	Vendor Name	SFP vendor name (ASCII)	43
21				4F
22				54
23				53
24				57
25				4F
26				52
27				4B
28				53
29				20
30				20
31				20
32				20
33				20
34				20
35				20
36	1	Transceiver	Code for electronic or optical compatibility	00
37	3	Vendor OUI	SFP vendor IEEE company ID	00
38				00
39				00
40	16	Vendor PN	Part number provided by SFP vendor (ASCII)	53





41				46
42				42
43				47
44				33
45				35
46				XX
47				XX
48				XX
49				XX
50				XX
51				XX
52				XX
53				XX
54				XX
55				XX
56				30
57	4	Vendor rev	Revision level for part number provided by vendor (ASCII)	30
58				30
59				30
60				30
61	2	Wavelength	Laser wavelength	05
62				1E
62	1	Unallocated		00
63	1	CC_BASE	Check code for Base ID Fields (addresses 0 to 62)	XX
Extended ID Fields				
64	2	Options	Indicates which optional transceiver signals are implemented	00
65				14
66	1	BR, max	Upper bit rate margin, units of %	00
67	1	BR, min	Lower bit rate margin, units of %	00
68	16	Vendor SN	Serial number provided by vendor (ASCII)	XX
69				XX
70				XX
71				XX
72				XX
73				XX
74				XX
75				XX
76				XX
77				XX
78				XX
79				XX
80				XX
81				XX
82				XX
83				XX
84	8	Date code	Vendor's manufacturing date code	XX
85				XX
86				XX
87				XX
88				XX
89				XX
90				20
91				20
92	1	Diagnostic Monitoring Type	Indicates which type of diagnostic monitoring is implemented (if any) in the transceiver	68



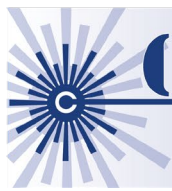

93	1	Enhanced Options	Indicates which optional enhanced features are implemented (if any) in the transceiver	00
94	1	SFF-8472 Compliance	Indicates which revision of SFF-8472 the transceiver complies with	05
95	1	CC_EXT	Check code for the Extended ID Fields (addresses 64 to 94)	XX

Address A0h Data Fields (SFB-G-53)

A0h Address (dec)	# Bytes	Name	Description	Value (hex)
Base ID Fields				
00	1	Identifier	Type of transceiver	02
01	1	Ext. Identifier	Extended identifier of type of transceiver	04
02	1	Connector	Code for connector type	07
03	8	Transceiver	Code for electronic or optical compatibility	04
04				10
05				10
06				02
07				40
08				10
09				0D
10				01
11	1	Encoding	Code for high-speed serial encoding algorithm	01
12	1	BR, Nominal	Nominal signaling rate, units of 100MBd	0C
13	1	Rate Identifier	Type of rate select functionality	00
14	1	Length (SMF, km)	Link length supported for single mode fiber, units of km	02
15	1	Length (SMF)	Link length supported for single mode fiber, units of 100m	14
16	1	Length (50µm)	Link length supported for 50µm OM2 fiber, units of 10m	37
17	1	Length (62.5µm)	Link length supported for 62.5µm OM1 fiber, units of 10m	1C
18	1	Length (OM4 or copper cable)	Link length supported for 50µm OM4 fiber, units of 10m. Alternatively copper or direct attach cable, units of m	64
19	1	Length (OM3)	Link length supported for 50µm OM3 fiber, units of 10m	37
20	16	Vendor Name	SFP vendor name (ASCII)	43
21				4F
22				54
23				53
24				57
25				4F
26				52
27				4B
28				53
29				20
30				20
31				20
32				20



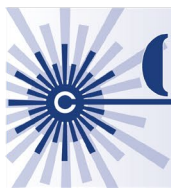

33				20
34				20
35				20
36	1	Transceiver	Code for electronic or optical compatibility	00
37				00
38	3	Vendor OUI	SFP vendor IEEE company ID	00
39				00
40				53
41				46
42				42
43				47
44				33
45				35
46				XX
47	16	Vendor PN	Part number provided by SFP vendor (ASCII)	XX
48				XX
49				XX
50				XX
51				XX
52				XX
53				XX
54				XX
55				XX
56				30
57	4	Vendor rev	Revision level for part number provided by vendor (ASCII)	30
58				30
59				30
60				06
61	2	Wavelength	Laser wavelength	0E
62	1	Unallocated		00
63	1	CC_BASE	Check code for Base ID Fields (addresses 0 to 62)	XX
Extended ID Fields				
64	2	Options	Indicates which optional transceiver signals are implemented	10
65				14
66	1	BR, max	Upper bit rate margin, units of %	00
67	1	BR, min	Lower bit rate margin, units of %	00
68				XX
69				XX
70				XX
71				XX
72				XX
73				XX
74				XX
75	16	Vendor SN	Serial number provided by vendor (ASCII)	XX
76				XX
77				XX
78				XX
79				XX
80				XX
81				XX
82				XX
83				XX
84	8	Date code	Vendor's manufacturing date code	XX





85				XX
86				XX
87				XX
88				XX
89				XX
90				20
91				20
92	1	Diagnostic Monitoring Type	Indicates which type of diagnostic monitoring is implemented (if any) in the transceiver	68
93	1	Enhanced Options	Indicates which optional enhanced features are implemented (if any) in the transceiver	70
94	1	SFF-8472 Compliance	Indicates which revision of SFF-8472 the transceiver complies with	8
95	1	CC_EXT	Check code for the Extended ID Fields (addresses 64 to 94)	XX





Application Schematics

HOST BOARD APPLICATION SCHEMATIC (AC-COUPLED)

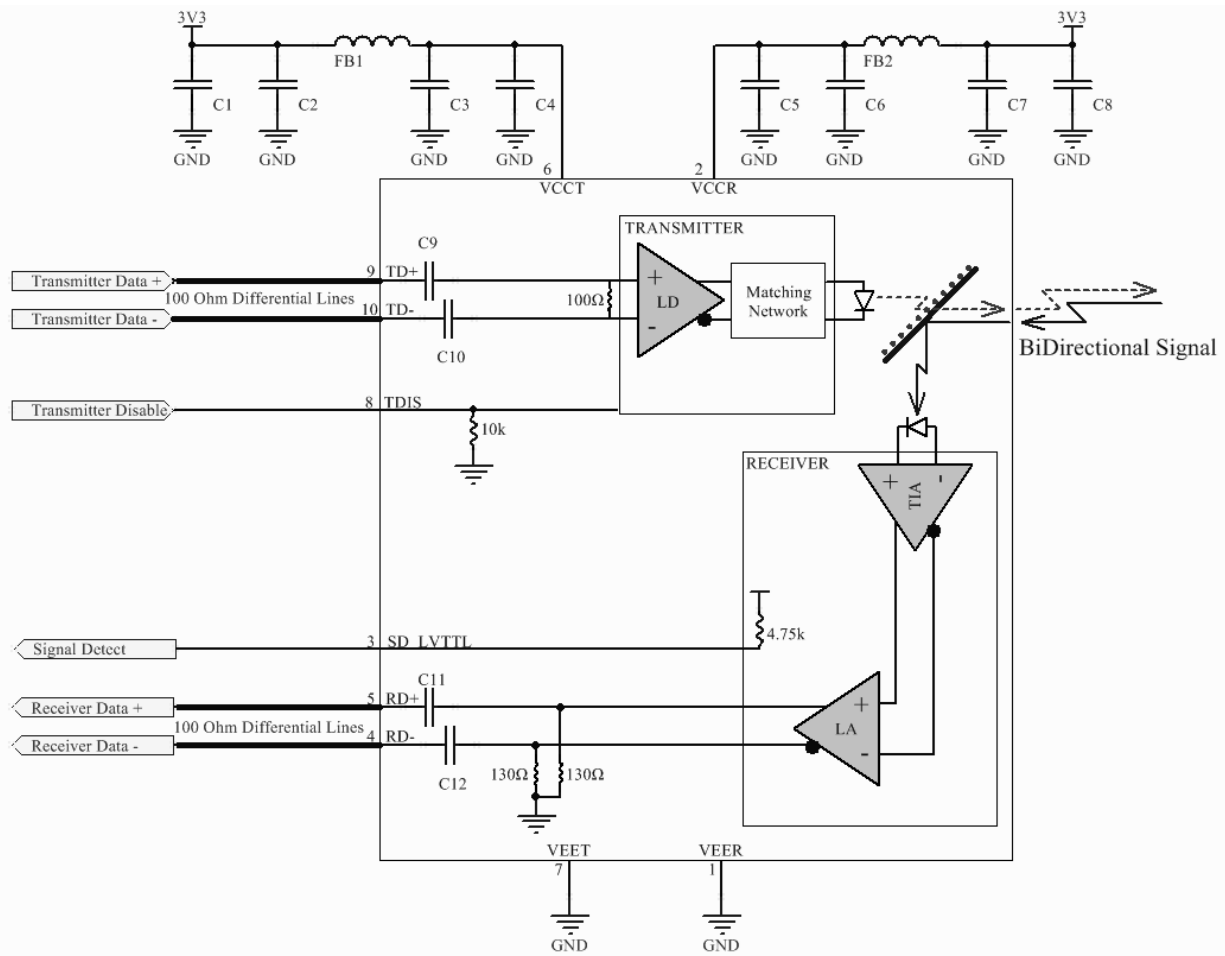
**Notes:**

- Recommend host routes separate supply voltages and filtering for SFF-module transmitter and receiver as shown in the schematic above
 - FB1/FB2 ferrite bead for power supply noise suppression; Murata BLM18KG601SN1, 0603, 600Ω @ 100MHz, 1300mA
 - C1/C4/C5/C8 bulk capacitance; Murata GRM21BR61C106KE15L, 0805, 10μF, 16V
 - C2/C3/C6/C7 de-coupling capacitors; Murata GRM155R71C104KA88D, 0402, 0.1μF, 16V
 - C9/C10/C11/C12 X7R 0.1μF, 16V coupling capacitors
- Mounting studs/solder posts must be connected to chassis ground in a bezel mounted application
- Recommend mounting studs/solder posts be connected to chassis ground if available in embedded applications. Otherwise they should be tied to local signal ground
- Design is intrinsically laser eye safe in accordance with EN/IEC 60825-1, no TX_FAULT circuit is required





Mounting Hardware Guidelines

2x5 Pin Option (No Digital Diagnostics)

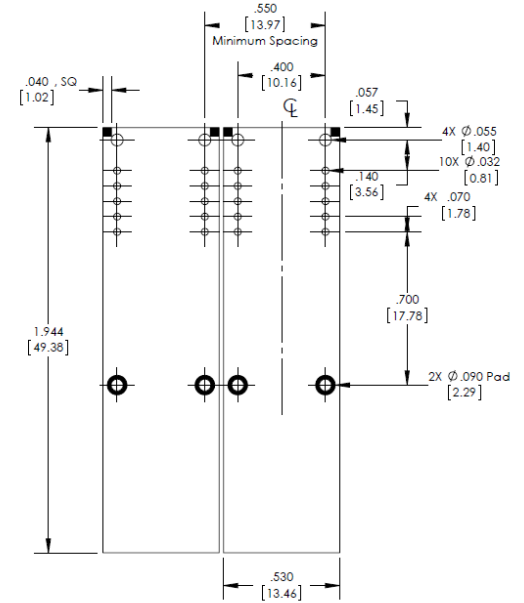
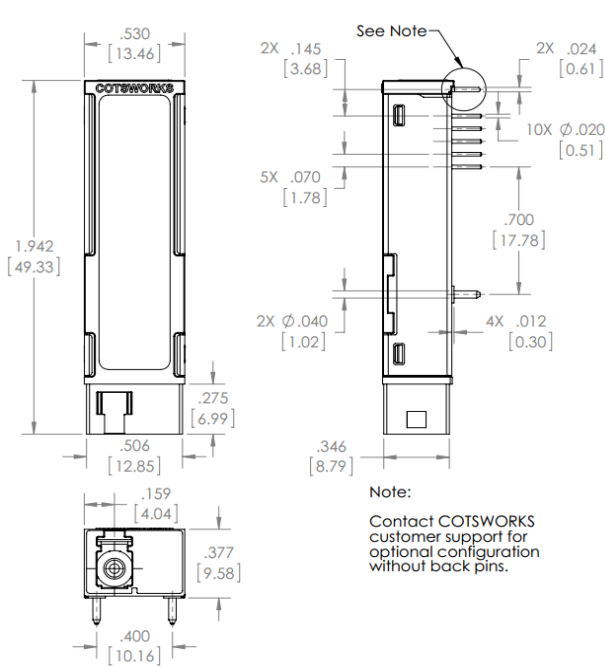

2x7 Pin Option (Digital Diagnostics)

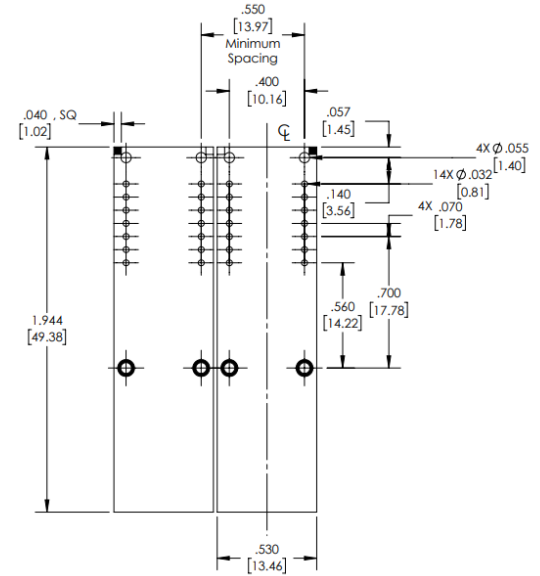
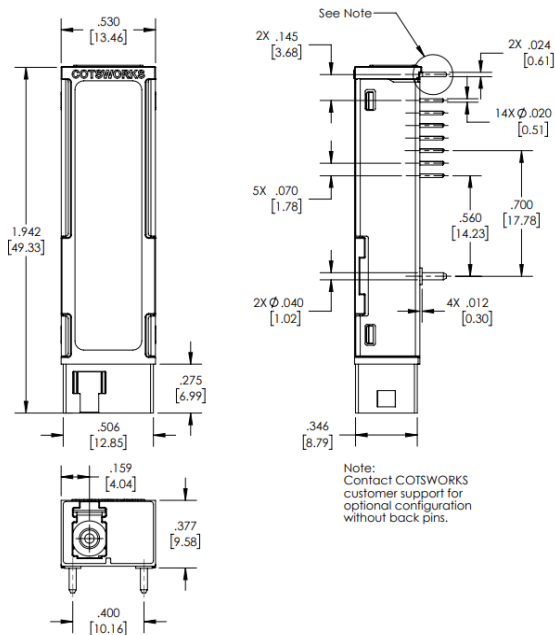

Dimensions are defined by the Small Form Factor (SFF) Transceiver Multi-source Agreement (MSA). July 5, 2000.





Ruggedization Notes

- A conformal coating of at least 0.8mil and not exceeding 1.2mil is applied to the PWB on both sides.
- The coating material is Parylene® Type C. It is applied to meet Type C Military specification 46085C.
- Contact COTSWORKS for MSDS, case composition and burn analysis information.

Warnings:

Handling Precautions: This device is susceptible to damage from electrostatic discharge (ESD). A static free environment is highly recommended.

Laser Safety: Radiation emitted by laser devices can be dangerous to human eyes. Avoid eye exposure to direct or indirect radiation.

Ordering Information

SFB-G-	xx	-x-	x	-x-	x
SFF Form Factor	Wavelength	Pins and Diagnostics	Coating	Operating Temp Range	Post Option
Single Fiber	35: 1310Tx/1550Rx	(): 2x5 - No Diagnostics	(): Non-coated	A: -40 to 85°C	(): No Posts
1.25Gbps	53: 1550Tx/1310Rx	D: 2x7 - Digital Diagnostics	R: Parylene		P: Solder Posts*

Example part number: SFB-G-35-R-A

[Single Fiber (bi-directional) SFF, 1.25Gbps, 1310nm Tx, 1550nm RX, Parylene-coated, industrial operating temp range]

*Solder post option includes 90/10 tin/lead plating to enable soldering to host PCB while mitigating tin-whiskering concerns. No post option includes no plating.

Contact COTSWORKS for mechanical dimensional information and other configuration options.

COTSWORKS and the COTSWORKS logo are registered trademarks of COTSWORKS, INC. COTSWORKS reserves the right to change, alter, or revise this document without notice unless otherwise agreed to.

